

REVISIONS			
REV	DESCRIPTION	DATE	APPROVED
--	--	--	--

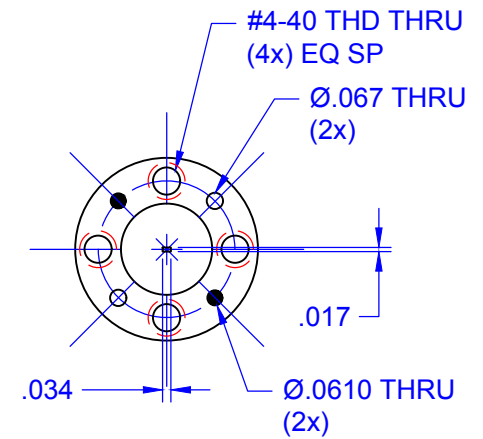
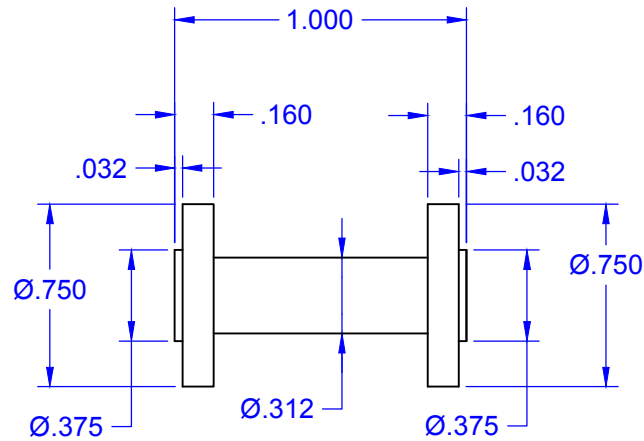
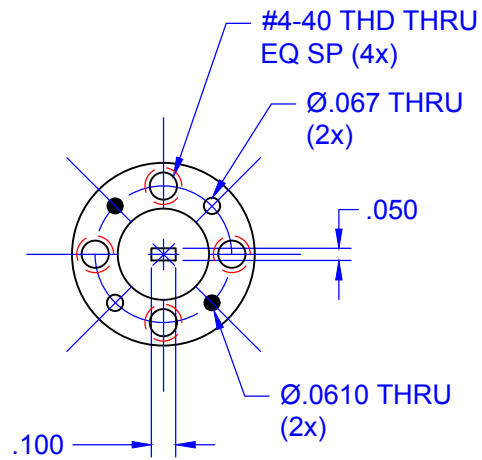
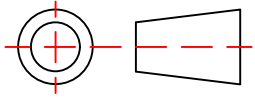

--	--	MATERIAL: 1/2 HARD BRASS		--
QTY	PART NUMBER	DESCRIPTION		ITEM
UNLESS OTHERWISE SPECIFIED ALL SURFACES $\sqrt{32}$		 THIRD ANGLE PROJECTION		Mi-Wave Millimeter Products Inc. 692W-J/387 OUTLINE
DIMENSIONS ARE IN INCHES TOLERANCES ARE: DECIMALS: .1234 +/- .0005 .123 +/- .005 .12 +/- .01 ANGLES: +/- .5 DEGREES				
ALL THREADS TO BE 2A OR 2B		DRAFTING: K.S.	SIZE A	
REF DWG# --		APPROVED: M.S.		
		DATE: 5/2/2016	DWG NO	24945
		SHEET NO. 1 OF 1		